

REVISIONS			
REV	DESCRIPTION	DATE	APPROVED

ELECTRICAL SPECIFICATIONS

Frequency: 1.000 MHz
 Frequency Tolerance (Ref @ +25°C): ± 100 ppm Max.
 Frequency Stability (0 to +60°C): ± 100 ppm Max.
 Crystal Cut: SL
 Load Capacitance (CL): 13 pF
 Recommended Drive Level: 500 µW Max.
 Effective Series Resistance: 3000 Ω Max.
 Insulation Resistance: 500 Megaohms Min. @ 100 Vdc
 Shunt Capacitance: 7 pF Max.
 Mode of Operation: Fundamental
 Aging: ± 10 ppm/year Max.
 Storage Temperature: -30 to +85°C
 Operating Temperature: 0 to +60°C
 Package Type: HC-49U

Dimensions (mm)

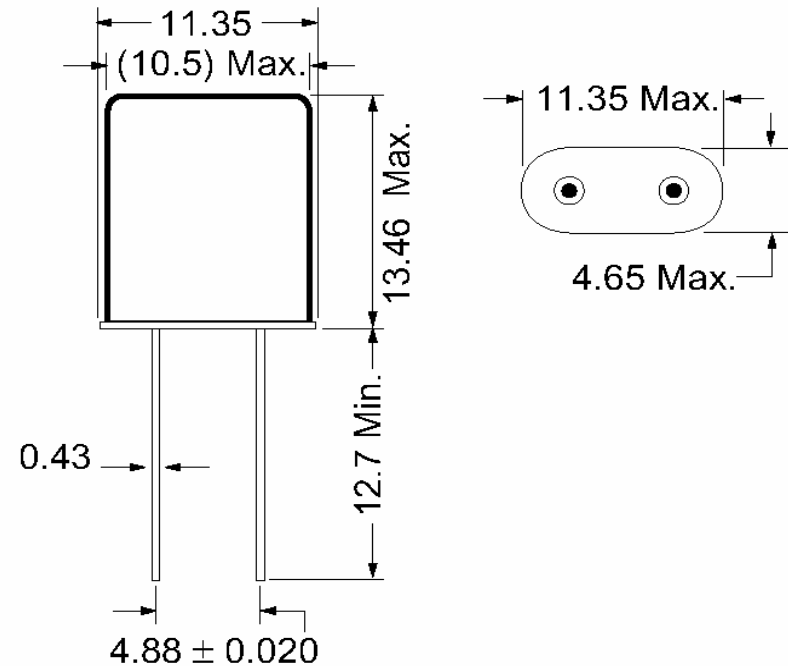

Figure 1) Side and bottom view

ECS Part Number: ECS-10-13-1XH



ECS INC. INTERNATIONAL 1105 S. Ridgeview Olathe, KS 66062 (913) 782-7787		
TITLE 1.000 MHz Crystal, HC-49U 13 pF Load Capacitance, SL Cut		
SIZE A	DWG NO. ECS-10-13-1XH	REV -
CAGE CODE: 1G8B7		SHEET 1 OF 1

SIGNATURES	DATE
DRN MR	4/18/2007
CHK DK	4/18/2007
APP BS	4/18/2007
Dimensions in mm	